





General Instructions

- This examination has **3 problems**.
- Before the start of the practical exam, the **READ** signal is given. You will have 15 minutes to read the exam booklet. You may **only read** during this time. **Do not write nor use the calculator. Do not work on any problem nor interact with any equipment.**
- You may begin working as soon as the **START** signal is given. You will then have **5 hours** to complete the exam.
- Each signal is given by the ringing of a cowbell.
- You may do practical work on **only P3 first for up to 60 minutes**. During this time you will only have access to the chemicals and equipment for P3 which are on your bench. Signals after 50 and 60 minutes will be given.
- Once finished with practical work on P3, raise the technical assistance card. A supervisor will **collect all chemicals and equipment used only for P3**. Question and answer sheets for P3 will not be collected. After this, you can start working on P1 and P2. The chemicals and equipment for these tasks are stored in the cabinet below your workspace.
- All results and answers must be clearly written in pen **in their respective designed areas on the answer sheets**. Answers written outside the answer boxes will not be graded. Some figures are reproduced in your question sheets for scratch work. They will not be graded. **Make sure to copy your final answer to your answer sheets.**
- For the multiple choice questions, **if you want to change your answer**, shade the check box completely and then make a new box next to it. Mark your intended answer with a check.
- Use only the pen (in Box "P3") and calculator provided.
- The official English version of the exam booklet is available upon request and serves for clarification only.
- Shelves above the benches are **not** to be used during the task for the purpose of equality.
- You may use the **cabinets** below your work space to store any material. The cabinets become available after handing in materials for only P3.

- You must **follow the safety rules** given in the IChO regulations. Any safety rule violation can result in your dismissal from the laboratory and the nullification of your practical examination.
- Chemicals and labware, unless otherwise noticed, will be refilled or replaced without penalty only for the first incident (one item). Each further incident will result in the deduction of 1 point from your 40 practical exam points.
- **Only chemicals** listed in a problem may be used to solve that problem. Failure to comply will result in the nullification your practical exam.
- When necessary or instructed to do so, **wash your glassware at your workspace**. The sinks must not be used for washing glassware.
- The supervisors will announce a **30-minute** warning before the **STOP** signal.
- You must stop your work immediately when the **STOP** signal is announced. Failure to stop working or writing can lead to nullification of your practical exam.
- After the **STOP** signal has been given, the lab supervisor will come to sign your answer sheet.
- After both the supervisor and you sign, put **all sheets with the cover sheet on top** back into the envelope. **Do not seal** the envelope. Submit it for grading together with your products and thin-layer chromatography (TLC) plates.
- You are not allowed to leave your working place without permission. If you need any assistance, raise the corresponding nonverbal communication card (see table below for meanings).
- **Do not** draw anything into or close to the QR codes.

			
I need to use the toilet, grab a snack, or take a break	I need technical assistance	I have a medical emergency	I need to see the official English version for clarification

Meanings of the non-verbal communication cards.

Practical



55TH INTERNATIONAL
CHEMISTRY OLYMPIAD
SWITZERLAND 2023

G0-3
English (Official)

GOOD LUCK!

Problems and Grading Information

	Title	Question Pages	Answer Pages	Total Score	Percentage
1	Bleach, a Chameleonic Reagent	10	4	70	16
2	Titration Tango	4	4	90	13
3	Beauty in Simplicity	2	4	59	11
				Total	40

Physical Constants and Equations

Constants

Planck constant	$h = 6.626 \cdot 10^{-34} \text{ J s}$
Boltzmann constant	$k_B = 1.381 \cdot 10^{-23} \text{ kg m}^2 \text{ s}^{-2} \text{ K}^{-1}$
Speed of Light	$c = 2,99792458 \cdot 10^8 \text{ m s}^{-1}$
Elementary charge	$e = 1.602 \cdot 10^{-19} \text{ C}$
Avogadro constant	$N_A = 6.022 \cdot 10^{23} \text{ mol}^{-1}$
Universal gas constant	$R = 8.314 \text{ J mol}^{-1} \text{ K}^{-1}$
Faraday constant	$F = 96485 \text{ C mol}^{-1}$
Standard pressure	$p_0 = 1 \cdot 10^5 \text{ Pa}$
Electronvolt	$1 \text{ eV} = 1.602 \cdot 10^{-19} \text{ J}$
Electric Charge & Current	$1 \text{ C} = 1 \text{ A} \cdot 1 \text{ s}$
Absolute zero	$0 \text{ K} = -273.15 \text{ }^\circ\text{C}$
Ångstrom	$1 \text{ \AA} = 10^{-10} \text{ m}$
pico	$1 \text{ pm} = 10^{-12} \text{ m}$
nano	$1 \text{ nm} = 10^{-9} \text{ m}$
micro	$1 \text{ }\mu\text{m} = 10^{-6} \text{ m}$
milli	$1 \text{ mm} = 10^{-3} \text{ m}$
centi	$1 \text{ cm} = 10^{-2} \text{ m}$
deci	$1 \text{ dm} = 10^{-1} \text{ m}$
kilo	$1 \text{ km} = 10^3 \text{ m}$
mega	$1 \text{ Mm} = 10^6 \text{ m}$
giga	$1 \text{ Gm} = 10^9 \text{ m}$
tera	$1 \text{ Tm} = 10^{12} \text{ m}$
Pi (π)	$\pi = 3.141592 \dots$
Euler's number	$e = 2.718281 \dots$

Equations

Ideal gas law	$pV = nRT = Nk_B T$
Gibbs free energy	$\Delta G = \Delta H - T\Delta S$ $\Delta G^\circ = -RT \ln K^\circ$ $\Delta_r G^\circ = -nFE_{cell}^\circ$ where n is the number of electrons $\Delta_r G = \Delta_r G^\circ + RT \ln Q$
Reaction quotient Q for reaction: $aA + bB \rightleftharpoons cC + dD$	$Q = \frac{[C]^c [D]^d}{[A]^a [B]^b}$
Nernst equation	$E = E_0 - \frac{RT}{nF} \ln Q$
Electric current	$I = Q/t$
Faraday equation	$I \cdot t = n \cdot z \cdot F$
Energy of charge q in electric field	$E = k \frac{q_1 q_2}{d}$
Arrhenius law	$k = A \exp\left(\frac{-E_A}{RT}\right)$
Lambert Beer equation	$A = \epsilon lc$
Henderson-Hasselbalch equation	$\text{pH} = \text{pK}_a + \log\left(\frac{[A^-]}{[HA]}\right)$
Energy of a photon	$E = h\nu = \frac{hc}{\lambda}$
Integrated rate laws for ...	
... zeroth order	$[A] = [A]_0 - kt$
... first order	$\ln[A] = \ln[A]_0 - kt$
... second order	$\frac{1}{[A]} = \frac{1}{[A]_0} + kt$
Half life for a first order reaction	$t_{1/2} = \frac{\ln 2}{k}$
Half life for a second order process	$t_{1/2} = \frac{1}{[A]_0 k}$
Radioactivity	$A = k \cdot N$
Surface area of a sphere with radius R	$A = 4\pi R^2$
Volume of a sphere with radius R	$V = \frac{4\pi}{3} R^3$

Periodic Table of the Elements

1 H 1.008																	2 He 4.003
3 Li 6.94																	9 F 19.00
4 Be 9.01																	8 O 16.00
11 Na 22.99																	17 Cl 35.45
12 Mg 24.31																	16 S 32.06
19 K 39.10	20 Ca 40.08	21 Sc 44.96	22 Ti 47.87	23 V 50.94	24 Cr 52.00	25 Mn 54.94	26 Fe 55.85	27 Co 58.93	28 Ni 58.69	29 Cu 63.55	30 Zn 65.38	31 Ga 69.72	32 Ge 72.63	33 As 74.92	34 Se 78.97	35 Br 79.90	36 Kr 83.80
37 Rb 85.47	38 Sr 87.62	39 Y 88.91	40 Zr 91.22	41 Nb 92.91	42 Mo 95.95	43 Tc [98]	44 Ru 101.07	45 Rh 102.91	46 Pd 106.42	47 Ag 107.87	48 Cd 112.41	49 In 114.82	50 Sn 118.71	51 Sb 121.76	52 Te 127.60	53 I 126.90	54 Xe 131.29
55 Cs 132.91	56 Ba 137.33	57-71 La [226]	72 Hf 178.49	73 Ta 180.95	74 W 183.84	75 Re 186.21	76 Os 190.23	77 Ir 192.22	78 Pt 195.08	79 Au 196.97	80 Hg 200.59	81 Tl 204.38	82 Pb 207.2	83 Bi 208.98	84 Po [209]	85 At [210]	86 Rn [212]
87 Fr [223]	88 Ra [226]	89-103 Ac [227]	104 Rf [267]	105 Db [268]	106 Sg [269]	107 Bh [270]	108 Hs [270]	109 Mt [278]	110 Ds [281]	111 Rg [282]	112 Cn [285]	113 Nh [286]	114 Fl [289]	115 Mc [290]	116 Lv [293]	117 Ts [294]	118 Og [294]
57 La 138.91	58 Ce 140.12	59 Pr 140.91	60 Nd 140.24	61 Pm [145]	62 Sm 150.36	63 Eu 151.96	64 Gd 157.25	65 Tb 158.93	66 Dy 162.50	67 Ho 164.93	68 Er 167.26	69 Tm 168.93	70 Yb 173.05	71 Lu 174.97			
89 Ac [227]	90 Th 232.04	91 Pa 231.04	92 U 238.03	93 Np [237]	94 Pu [244]	95 Am [243]	96 Cm [247]	97 Bk [247]	98 Cf [251]	99 Es [252]	100 Fm [257]	101 Md [258]	102 No [259]	103 Lr [266]			

Safety

When in the laboratory students must respect the rules:

- Do not eat or drink in the lab. Chewing gum is not allowed.
- Work only in the designated area. Keep your work area and the common work areas tidy.
- No unauthorized experiments are allowed. No modification of the experiments is allowed.
- Vials and screw capped bottles must be kept closed whenever possible.
- Do not pipette with your mouth. Always use a pipette filler bulb.
- Inform your lab assistant about spills and broken glassware immediately. Inform the assistants about any accident.
- All waste must be properly discarded to prevent contamination or injury. Dispose the solutions in the containers with the correct labels. If any containers is full inform your lab assistant.
- Contact lenses are prohibited in the laboratory.

During the examination, the students will be required to wear:

- pants covering their whole legs;
- closed and flat shoes;
- a lab coat with long sleeves;
- safety goggles fitting the contour of their face;
- if applicable, long hair and beards tied back.

Any student that would fail to respect these rules will not be allowed to enter the lab along with the nullification of their practical exam and exclusion from the practical exam.

GHS Statements

The GHS hazard and precautionary statements associated with the materials used are indicated in the problems. Their meanings are as follows:

H-phrases Physical Hazards

H224: Extremely flammable liquid and vapour

H225: Highly flammable liquid and vapour

H226: Flammable liquid and vapour

H260: In contact with water releases flammable gases which may ignite spontaneously

H272: May intensify fire: oxidizer

H290: May be corrosive to metals

H-phrases Health Hazards

H301: Toxic if swallowed

H301+H331: Toxic if swallowed or if inhaled

H302: Harmful if swallowed

H302+H312: Harmful if swallowed or in contact with skin

H302+H312+H332: Harmful if swallowed, in contact with skin or if inhaled

H302+H332: Harmful if swallowed or inhaled

H304: May be fatal if swallowed and enters airways

H311: Toxic in contact with skin

H311+H331: Toxic in contact with skin or if inhaled

H312: Harmful in contact with skin

H312+H332: Harmful in contact with skin or if inhaled

H314: Causes severe skin burns and eye damage

H315: Causes skin irritation

H317: May cause an allergic skin reaction

H318: Causes serious eye damage

H319: Causes serious eye irritation

H331: Toxic if inhaled

H332: Harmful if inhaled

H335: May cause respiratory irritation

H336: May cause drowsiness or dizziness

H351: Suspected of causing cancer

H361: Suspected of damaging fertility or the unborn child

H361d: Suspected of damaging the unborn child

H361f: Suspected of damaging fertility

H371: May cause damage to organs

H372: Causes damage to organs through prolonged or repeated exposure

H373: May cause damage to organs through prolonged or repeated exposure

H-phrases Environmental Hazards

H400: Very toxic to aquatic life

H410: Very toxic to aquatic life with long lasting effects

H411: Toxic to aquatic life with long lasting effects

H412: Harmful to aquatic life with long lasting effects

H441: Very toxic to terrestrial invertebrates

Prevention precautionary statements

P202: Do not handle until all safety precautions have been read and understood.

P210: Keep away from heat, hot surfaces, sparks, open flames and other ignition sources. No smoking.

P220: Keep/Store away from clothing/.../combustible materials.

P223: Do not allow contact with water.

P231: Handle and store contents under inert gas/...

P232: Protect from moisture.

P233: Keep container tightly closed.

P234: Keep only in original container/packaging.

P235: Keep cool.

P240: Ground and bond container and receiving equipment.

P241: Use explosion-proof electrical/ventilating/light/.../equipment.

P242: Use only non-sparking tools.

P243: Take action to prevent static discharges.

P260: Do not breathe dust/fume/gas/mist/vapours/spray.

P261: Avoid breathing dust/fume/gas/mist/vapours/spray.

P264: Wash ... thoroughly after handling.

P270: Do not eat, drink or smoke when using this product.

P271: Use only outdoors or in a well-ventilated area.

P273: Avoid release to the environment.

P280: Wear protective gloves/protective clothing/eye protection/face protection.

Response precautionary statements

P301: IF SWALLOWED:

P301+P310: IF SWALLOWED: Immediately call a POISON CENTER or doctor/physician.

P301+P312: IF SWALLOWED: Call a POISON CENTER or doctor/physician if you feel unwell.

P301+P330+P331: IF SWALLOWED: Rinse mouth. Do NOT induce vomiting.

P302: IF ON SKIN:

P302+P352: IF ON SKIN: Wash with soap and water.

P303: IF ON SKIN (or hair):

P303+P361+P353: IF ON SKIN (or hair): Remove/Take off immediately all contaminated clothing. Rinse skin with water [or shower].

P304: IF INHALED:

P304+P340: IF INHALED: Remove victim to fresh air and keep at rest in a position comfortable for breathing.

P305: IF IN EYES:

P305+P351+P338: IF IN EYES: Rinse continuously with water for several minutes. Remove contact lenses if present and easy to do. Continue rinsing.

P308: IF exposed or concerned:

P308+P311: IF exposed or concerned: Call a POISON CENTER or doctor/physician.

P310: Immediately call a POISON CENTER or doctor/physician.

P311: Call a POISON CENTER or doctor/physician.

P312: Call a POISON CENTER or doctor/physician if you feel unwell.

P313: Get medical advice/attention.

P314: Get Medical advice/attention if you feel unwell.

P315: Get immediate medical advice/attention.

P320: Specific treatment is urgent (see ... on this label).

P330: Rinse mouth.

P331: Do NOT induce vomiting.

P332: If skin irritation occurs:

P332+P313: If skin irritation occurs: Get medical advice/attention.

P337: If eye irritation persists:

P337+P313: If eye irritation persists: Get medical advice/attention.

P338: Remove contact lenses if present and easy to do. Continue rinsing.

P340: Remove victim to fresh air and keep at rest in a position comfortable for breathing.

P351: Rinse cautiously with water for several minutes.

P352: Wash with plenty of water.

P353: Rinse skin with water [or shower].

P361: Remove/Take off immediately all contaminated clothing.

P363: Wash contaminated clothing before reuse.

P370: In case of fire:

P370+P378: In case of fire: Use ... to extinguish.

P378: Use ... to extinguish.

P391: Collect spillage.

Storage precautionary statements

P403: Store in a well ventilated place.

P403+P233: Store in a well ventilated place. Keep container tightly closed.

P403+P235: Store in a well ventilated place. Keep cool.

P405: Store locked up.

P422: Store contents under ...

Disposal precautionary statements

P501: Dispose of contents/container to ...

List of Chemicals, Glassware, and Equipment

Problem 1: Organic Synthesis: Bleach, a Chameleonic Reagent

Chemical	Labelled as	Comment	GHS Statements
CH₃COOH , 4 mL	"AcOH"	Corrosive	H226, H314; P280, P210, P233, P240, P241, P242, P243, P260, P264, P280, P301+P330+P331, P302+P361+P354, P303+P361+P353, P304+P340, P305+P354+P338, P316, P321, P363, P370+P378, P403+P235, P405, P501
Eluent (C ₆ H ₁₄ /EtOAc, 80:20, v/v), 15 mL	"Eluent"	Flammable	Ethyl Acetate: H225, H319, H336; P210, P233, P240, P241, P242, P243, P261, P264+P265, P271, P280, P303+P361+P353, P304+P340, P305+P351+P338, P319, P337+P317, P370+P378, P403+P233, P403+P235, P405, P501. Hexane: H225, H304, H361f, H373, H315, H336, H411; P203, P210, P233, P240, P241, P242, P243, P260, P261, P264, P271, P273, P280, P301+P316, P302+P352, P303+P361+P353, P304+P340, P318, P319, P321, P331, P332+P317, P362+P364, P370+P378, P391, P403+P233, P403+P235, P405, P501
HCl , 2 M in H ₂ O, 25 mL	"2 M HCl"	Corrosive	H290, H314, H318, H335; P260, P280, P303+P361+P353, P305+P351+P338

p-Methoxyacetophenone , 2 x 500 mg	"SM-A" "SM-B"		H302, H315; P264, P270, P280, P301+P317, P302+P352, P321, P330, P332+P317, P362+P364, P501
NaHSO₃ (ca. 40% in H ₂ O), 8 mL	"NaHSO3 (aq)"		H302; P264, P270, P301+P317, P330, P501
NaOCl (ca. 14% in H ₂ O), 7.5 mL for preparation of product A, 4.0 mL for preparation of product B	"Bleach-A" "Bleach-B"	Corrosive	H314, H318, H400, H410; P260, P264, P264+P265, P273, P280, P301+P330+P331, P302+P361+P354, P304+P340, P305+P354+P338, P316, P317, P321, P363, P391, P405, P501
Na₂SO₄ , ca. 5 g	"Na2SO4"		H315, H318; P264, P264+P265, P280, P302+P352, P305+P354+P338, P317, P321, P332+P317, P362+P364
C₆H₅CH₃ , 40 mL	"Toluene"	Flammable	H225, H304, H315, H336, H361d, H373, H412; P203, P210, P233, P240, P241, P242, P243, P260, P261, P264, P271, P280, P301+P316, P302+P352, P303+P361+P353, P304+P340, P318, P319, P321, P331, P332+P317, P362+P364, P370+P378, P403+P233, P403+P235, P405, P501
Distilled water	"dest. Wasser"		Not hazardous according to Regulation (EC) no. 1272/2008
NaOH (1 M in H ₂ O), 6.7 mL	"NaOH (aq)"	Corrosive	H290, H314; P260, P264, P280, P301+P330+P331, P302+P361+P354, P304+P340, P305+P354+P338, P316, P321, P363, P405, P501
(CH₃)₂CO	"Aceton"	Flammable	H225, H319, H336; P210, P233, P240, P241, P242, P305 + P351 + P338

Personal equipment	Quantity
Laboratory stand	1
Clamp with clamp holder	4
Magnetic stirrer with hotplate	1
Magnetic stir bar (rod-shaped, 2.5 cm)	2
Magnetic stir bar (olive-shaped, 2 cm long, 1 cm thick)	1
Water bath: crystallization dish (filled 1/3 with water, equipped with 1 magnetic stir bar)	1
Thermometer (0 – 100 °C)	1
Round-bottom flask (50 mL)	2
Vigreux column	1
Hose adapter, bent, connected to gas bubbler	1
Gas bubbler with PVC hose, charged with trap solution (EtOH/aq. 1 M NaOH, 10:90, v/v)	1
Graduated cylinder (10 mL)	1
Graduated cylinder (50 mL)	1
Erlenmeyer flask (50 mL)	1
Suction flask (500 mL), with rubber protection sleeve and rubber gasket, connected to vacuum trap	1
Vacuum trap, connected to vacuum module	1
Glass filter crucible (8 mL)	1
Separatory funnel (50 mL) with plastic stopper	1
Glass funnel	1
TLC elution chamber with lid	1
TLC plate, in the ziplock bag labeled "TLC + [student code]"	3

TLC capillary	6
Vials (4 mL), labeled "TLC-SM", "TLC-A", and "TLC-B"	3
Vial (20 mL), labeled "Product A + [student code]"	1
Vials (20 mL), labeled "SM-A", "SM-B", "Bleach-A", "Bleach-B", "AcOH", "NaOH (aq)", "NaHSO ₃ (aq)", "Na ₂ SO ₄ "	8
Bottles (50 mL), labeled "Eluent", "Toluene", and "2 M HCl"	3
Volumetric flask (50 mL), labeled "Product B + [student code]"	1
Pasteur pipette	12
Beaker (100 mL)	1
Spatula (large)	1
Spatula (small)	1
Tweezers	1
Joint clip	1
Cork ring	1
pH Indicator strip, in the ziplock bag labeled "TLC +[student code]"	10
Filter paper	1
Pencil	1
Ruler	1
Squeeze wash bottle for acetone (500 mL)	1
Bottle for aqueous waste (250 mL), labelled " Waste (aq) ", pre-charged with Na ₂ S ₂ O ₃ solution	1
Bottle for organic waste (100 mL), labelled " Waste (org) "	1
Weighing paper	3

Shared equipment	Quantity (per lab, 20 capita)
UV lamp	1
Magnetic stir bar remover	2
Crushed ice, bucket	2

Problem 2: Titration Tango

Chemical	State	Comment	GHS Hazard Statements
CaCl₂·2H₂O	Solid	in vial labeled " CaCl₂·2H₂O + [student code] + [mass]"	H319; P264, P280, P305 + P351 + P338, P337 + P313
Distilled water	Liquid	In wash bottle labeled " dest. Wasser "	Not a hazardous substance or mixture according to Regulation (EC) No. 1272/2008
EDTA standard solution (10.0 mM)	Liquid	500 mL, in PE bottle labeled " EDTA "	H290, H314, H335; P234, P261, P271, P280, P303 + P361 + P353, P305 + P351 + P338
0.1 M HCl	Liquid	10 mL, corrosive, in vial labeled " 0.1 M HCl "	H290; P234, P390
Sample (mixture), dissolved in HCl, pH = 1	Liquid	in vial labeled " Sample + [student code] + [mass]", corrosive	H290, H319; P234, P264, P280, P305 + P351 + P338, P337 + P313, P390
Eriochrome® Black T (1 wt. % in NaCl)	Solid	1 g, indicator, in vial labeled " Erio T "	H319, H411; P264, P273, P280, P305 + P351 + P338, P337 + P313, P391
Variamine Blue (1 wt. % in NaCl)	Solid	1 g, indicator, in vial labeled " Variamine "	H302, H312, H332; P264, P270, P301 + P312, P330, P501, P280, P302 + P352, P312, P322, P363, P261, P271, P304 + P340
Schwarzenbach buffer (pH = 10, c _{HB+} + c _B = 8.8 M)	Liquid	10 mL, containing NH ₄ Cl and NH ₃ , in vial labeled " Buffer "	H302, H314, H319, H335, H410; P261, P264, P270, P271, P273, P280, P303 + P361 + P353, P305 + P351 + P338, P310 + P312, P337 + P313
Ethanol	Liquid	200 mL, flammable, in 250 mL bottle labeled " EtOH "	H225, H319; P210, P233, P240, P241, P242, P305 + P351 + P338

Practical



55TH INTERNATIONAL
CHEMISTRY OLYMPIAD
SWITZERLAND 2023

E0-6

English (Official)

Item	Count
20 mL vial	6, labeled " CaCl₂·2H₂O + [student code] + [mass]", " 0.1 M HCl ", " Erio T ", " Sample + [student code] + [mass] ", " Variamine ", " Buffer "
Volumetric flask (100 mL)	1
Volumetric flask (250 mL)	1
Small funnel, fitting the burette	1
Spatula	1
Erlenmeyer flask (300 mL)	3
Volumetric pipette (5.0 mL)	1
Pipette bulb	1
Graduated cylinder (50 mL)	1
Glass Pasteur pipette	4
Burette (50 mL)	1
Laboratory stand with burette holder	1
PE bottle (500 mL), labeled " EDTA "	1
Bottle (250 mL), labeled " EtOH "	1
Beaker (50 mL)	1
Volumetric pipette (20.0 mL)	1
Beaker (1000 mL), labeled " Waste (P2) "	1

Problem 3: Beauty in Simplicity

Chemical	State	Comment	GHS Hazard Statements
Solutions S1-S6	Liquid	Corrosive, in vials labeled " S1 "/" S2 "/" S3 "/" S4 "/" S5 "/" S6 " + "[student code]"	H272, H290, H301, H302, H314, H315, H318, H319, H332, H335, H373, H400, H410, H411

Item	Count
Bottle (100 mL), labeled " Waste (P3) "	1
Sample vials (20 mL), labeled " S1 "/" S2 "/" S3 "/" S4 "/" S5 "/" S6 " + "[student code]"	6
Test tubes	18
Glass Pasteur pipettes	10
Test tube rack	1

Equipment shared among all problems

Personal Equipment for all Problems	Quantity
Pen, in box " P3 "	1
Felt pen, in box " P3 "	1
Rubber bulb for Pasteur pipettes, in box " P3 "	3
Protective gloves	(S, M, L, XL) available upon request to lab assistant
Paper towel roll	1
Squeeze wash bottle for water (500 mL), to be refilled w/o penalty at any time	1

Bleach, a Chameleonic Reagent - Solutions

16% of total													
Question	Yield A	TLC A	Deductions A	Yield B	TLC B	Deductions B	1.1	1.2	1.3	1.4	1.5	1.6	Total
Points	25	3	-6	25	3	-25	4	2	2	2	2	2	70
Score													

Experimental Procedure

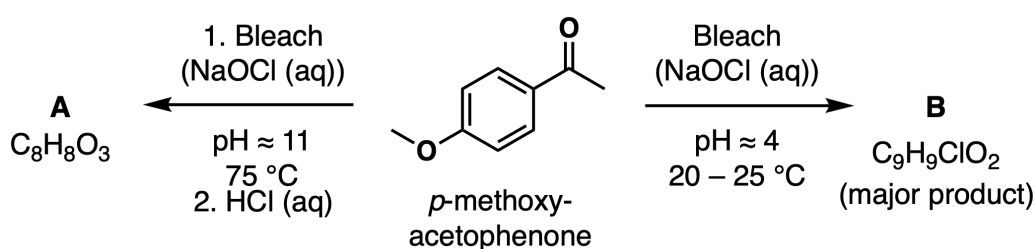

Legend for translation: Bleach, *p*-methoxyacetophenone, major product

Preparation of Product A

- Turn on** the magnetic stirrer hotplate and **set** the control knob between 100 °C and 150 °C in order to reach the desired water bath temperature of 70 – 80 °C. While stirring, **control** the temperature of the water bath with a thermometer clamped to the stand.
- While the water bath is heating up, **take** a small sample (small spatula tip) of *p*-methoxyacetophenone from the vial labeled "**SM-A**", **transfer** it to the vial labeled "**TLC-SM**" and **set** it **aside** for thin layer chromatography (TLC) analysis (to be carried out later).
- To a 50 mL round-bottom flask, **add** a stir bar (olive-shaped), *p*-methoxyacetophenone (500 mg, entire content of the vial labeled "**SM-A**", a weighing paper may be used for the transfer), NaOH (aq) (6.7 mL, entire content of the vial labeled "**NaOH (aq)**"), and bleach (7.5 mL, entire content of the vial labeled "**Bleach-A**").
- Clamp** the flask to the stand and **lower** it into the water bath by adjusting the position of the clamp. **Make sure** the reaction mixture is stirring rapidly (ca. 750 rpm).

- Attach** a Vigreux column to the flask (Figure 1). To the top of the Vigreux column, **attach** the bent hose adapter which is connected via tubing to a gas bubbler (filled with a trap solution of NaOH in EtOH/H₂O). **Secure** the joint with a clip.
- Let** the reaction **run** at 70 – 80 °C for 60 minutes.

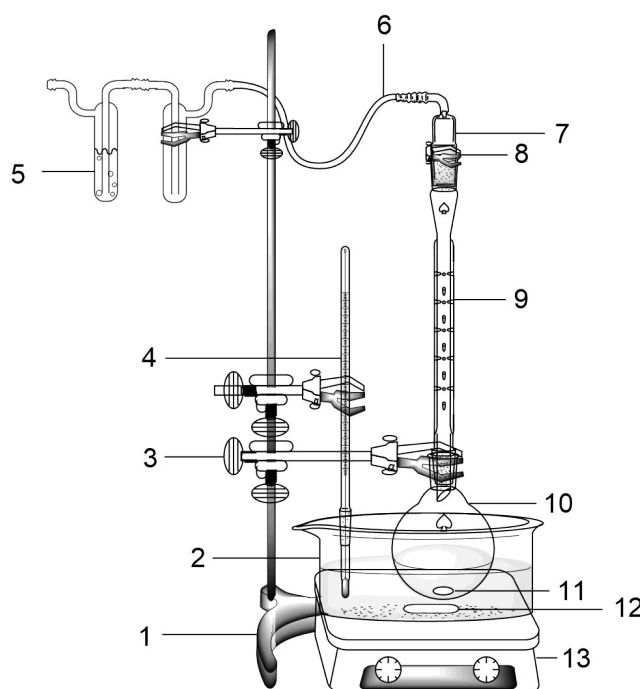

Figure 1: 1 = Laboratory stand, 2 = water bath, 3 = clamp holder with clamp, 4 = thermometer, 5 = gas bubbler, 6 = tubing, 7 = hose adapter with inner ground glass joint, 8 = joint clip, 9 = Vigreux column, 10 = round-bottom flask, 11 and 12 = magnetic stir bar, 13 = magnetic stirrer with hotplate

- Turn** off the heating, **raise** the flask above the water bath by adjusting the position of the clamps. **Raise** the technical assistance card for the removal of the water bath by an assistant. **Allow** the mixture to cool down while stirring and proceeding with the next steps.
- Disconnect** the gas bubbler from the Vigreux column by removing the bent hose adapter. **Remove** the Vigreux column (it will be reused in the preparation of product B).
- Ask** a lab assistant for crushed ice and **cool** the reaction flask in an ice-water bath while stirring (ca. 5 minutes).
- With the flask still in the ice-water bath, slowly **add** NaHSO₃ solution (aq, 40 %) (ca. 5 mL from the vial "**NaHSO₃ (aq)**"; 1 mL corresponds to ½ Pasteur pipette, see Figure 2) with a Pasteur pipette. **Keep** stirring. A white precipitate (product A) will form.

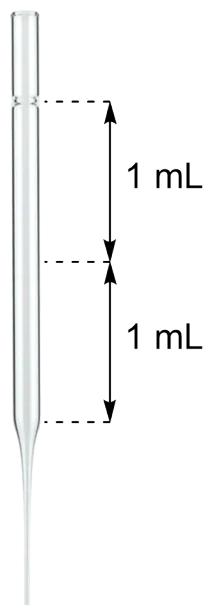

Figure 2: Pasteur pipette with approximate volume indications (scale 1:2)

11. **Adjust** the pH to 1-2 by adding 2 M HCl (aq) (ca. 6 – 8 mL, from the screw cap glass bottle labeled “2 M HCl (aq)”) with a Pasteur pipette. **Check** the pH of the solution, using pH indicator strips (for reference color pattern see Figure 3). To do so, **withdraw** a small aliquot of the reaction mixture with a fresh Pasteur pipette and **drip** a drop onto a pH indicator strip, **do not dip** the strips into the reaction mixture. **Continue** adding HCl until pH \approx 1-2, then **stop**.

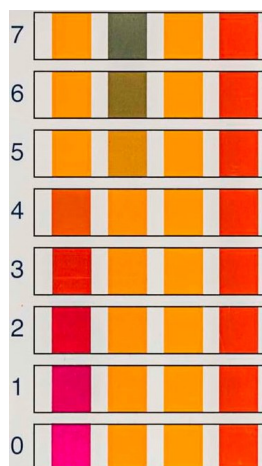

Figure 3: Color scale for pH determination by visual comparison with the reaction zones on the indicator strips. All four reaction zones on the pH paper strip have to match the color scale at the given pH value. The pH values are the numbers indicated on the left. You may ask your lab assistant to see the commercial product with the color scale printed on it.

12. **Ask** a lab assistant for a magnetic stir bar remover, **turn off** the stirrer and **remove** the stir bar from the flask. **Clean** the stir bar by rinsing it first with water (→ "Waste (aq)"), then with acetone (→ "Waste (org)") and **dry** it with a paper towel. It will be reused later.
13. **Set up** a vacuum filtration apparatus: **Clamp** the suction flask to the laboratory stand and **make sure** the conical rubber gasket is sitting on the rubber protection sleeve (Figure 4).

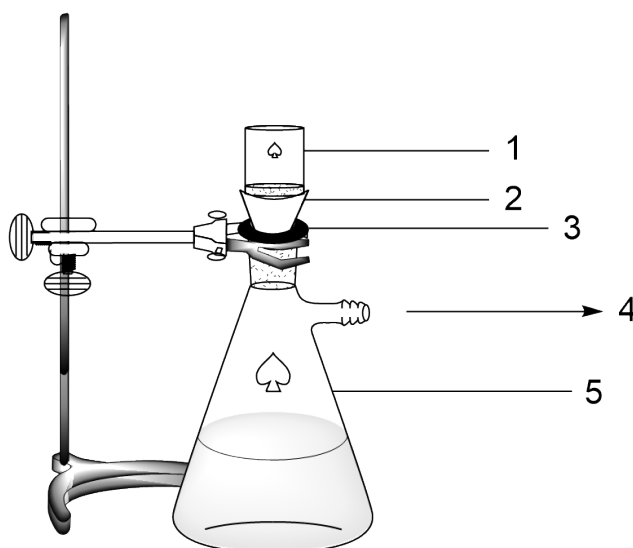

Figure 4: 1 = Glass filter crucible, 2 = conical rubber gasket, 3 = rubber protection sleeve, 4 = towards vacuum, 5 = suction flask

14. **Place** the glass filter crucible onto the conical rubber gasket. **Make sure** it fits tightly.
15. **Apply** vacuum and **pour** the suspension of the solid to be filtered into the glass filter crucible. Depending on the amount of liquid, this needs to be done portionwise.
16. **Wash** the solid thoroughly with water (2 x 10 mL; a measuring cylinder may be used).
17. **Let** air suck through the precipitate to remove most of the water (no more than 10 minutes), then **turn off** the vacuum and **disconnect** the vacuum source.
18. **Set aside** a small sample (1 small spatula tip) of product A in the glass vial labeled "TLC-A" for thin layer chromatography (TLC) analysis (to be carried out later).
19. **Transfer** the product from the glass filter crucible to the vial labeled "Product A + [student code]" with a spatula.



20. **Cap** the vial labeled “**Product A + [student code]**”. At the end of the exam, it will be picked up by your lab assistant.
21. **Dispose of** the filtrate (suction flask) in the “**Waste (aq)**” bottle.

Grading of Product A

Evaluation of TLC:

- Proper labelling: 1 pt
- Proper development: 1 pt
- Correct detection (circling) of spots 1 pt

Penalties:

- Submitted product too wet (not dry after 1 h in oven): -4 pt
- Product submitted in wrong vial: -2 pt

Grading of synthesis (yield) Reference points:

- 0% yield → 0 points (0% score)
- $0\% \leq x \leq 40\%$ yield → $x/4$ points
- 40% yield → 10 points (40% score)
- $40\% \leq x \leq 80\%$ yield → $(3x-40)/8$ points
- $80\% \leq x \leq 100\%$ yield → 25 points (100% score)
- $100\% < x \leq 110\%$ yield will be considered as 100%
- $x > 110\%$ yield will lead to 0 pt

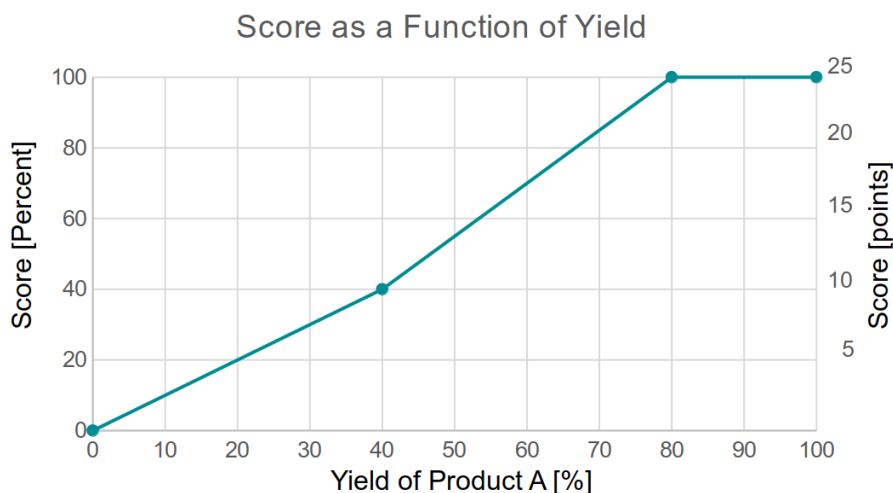

Points given for yield for Product A.

Preparation of product B

1. **Take** a fresh 50 mL round-bottom flask, add a magnetic stir bar (olive-shaped) and **clamp** the flask to the stand.
2. **Add** *p*-methoxyacetophenone (500 mg, entire content of the vial "SM-B", a weighing paper may be used for the transfer) and glacial acetic acid (4 mL, entire content of the vial "AcOH") to the flask.
3. While stirring, **add** bleach (4.0 mL, entire content of the vial "Bleach-B") **dropwise** over a period of 1 – 2 minutes, using a Pasteur pipette.
4. **Attach** a Vigreux column to the flask.
5. Rapidly **stir** the reaction (750 rpm) at room temperature for 45 minutes.
6. **Remove** the Vigreux column and dropwise **add** aqueous sodium bisulfite solution (40 %) (ca. 3 mL, remaining content of the vial "NaHSO₃ (aq)") to the mixture over a period of 1 minute, using a Pasteur pipette. The mixture warms up during the addition.
7. **Ask** a lab assistant for a magnetic stir bar remover, **turn off** the stirrer and **remove** the stir bar from the flask.
8. **Clamp** a 50 mL separatory funnel to the stand. **Add** 10 mL of water (a measuring cylinder may be used).
9. **Pour** the reaction mixture from the round-bottom flask via a glass funnel into the separatory funnel.



- Add** toluene (ca. 10 mL, from the screw cap bottle “Toluene”; a measuring cylinder may be used), then **remove** the funnel.
- Seal** the separatory funnel with a stopper and **shake** it vigorously for a while. **Make sure** to interrupt shaking and to vent the funnel from time to time, with its spout pointing away from yourself and others.
- Stop** shaking, **vent** the funnel one more time, then **clamp** it to the stand. **Remove** the stopper and **let** the layers separate.
- Drain** the lower (aqueous) layer into the used reaction flask (round-bottom flask). **Pour** the top (organic) layer containing product B into a 50 mL Erlenmeyer flask.
- Extract** the aqueous phase two more times with toluene by repeating steps 9 to 13 twice. **Collect** the organic extracts in the same Erlenmeyer flask.
- Rinse** the glass funnel with acetone (→ “Waste (org)”) and **let** it dry.
- Add** sodium sulfate (entire content of the vial “Na₂SO₄”) to the Erlenmeyer flask with the combined organic extracts. **Add** a stir bar (rod-shaped) and **stir** the suspension for 3 minutes on the magnetic stirrer, then **turn off** the stirrer.
- Let** the glass funnel sit on a clamp **have** its spout **protrude** into the volumetric flask labeled “Product B”. **Place** a filter paper into the glass funnel and **wet** it with a small amount of toluene using a Pasteur pipette.
- Filter** the contents of the Erlenmeyer flask into the volumetric flask “Product B” (the solution does not reach the mark). **Rinse** the Erlenmeyer flask with toluene (ca. 5 mL), using the same Pasteur pipette, and **pour** the solvent into the filter.
- With a Pasteur pipette, **transfer** 4 drops of your “product B” solution into the vial “TLC-B”.
- Stopper** the volumetric flask. At the end of the exam, it will be picked up by your lab assistant.
- Dispose of** the aqueous phase collected in the reaction flask (→ “Waste (aq)”).

Grading of Product B

Evaluation of TLC:

Practical - SOLUTIONS



55TH INTERNATIONAL
CHEMISTRY OLYMPIAD
SWITZERLAND 2023

S1-8

English (Official)

- Proper labelling: 1 pt
- Proper development: 1 pt
- Correct detection (circling) of spots: 1 pt

Deductions:

- Water droplets in toluene phase: -4 points
- Two-phase mixture: -6 points
- Formation of emulsion upon addition of toluene (sample preparation for GC analytics): -4 points
- Incomplete work-up (no extraction): -12 points
- Submission of aqueous instead of organic phase: -25 points

Grading of synthesis (yield) Reference points:

- 0% yield → 0 points (0% score)
- $0\% \leq x \leq 35\%$ yield → $2x/7$ points
- 35% yield → 10 points (40% score)
- $35\% \leq x \leq 70\%$ yield → $(3x-35)/7$ points
- $70\% \leq x \leq 100\%$ yield → 25 points (100% score)
- $100\% < x \leq 110\%$ yield will be considered as 100%
- $x > 110\%$ yield will lead to 0 pt

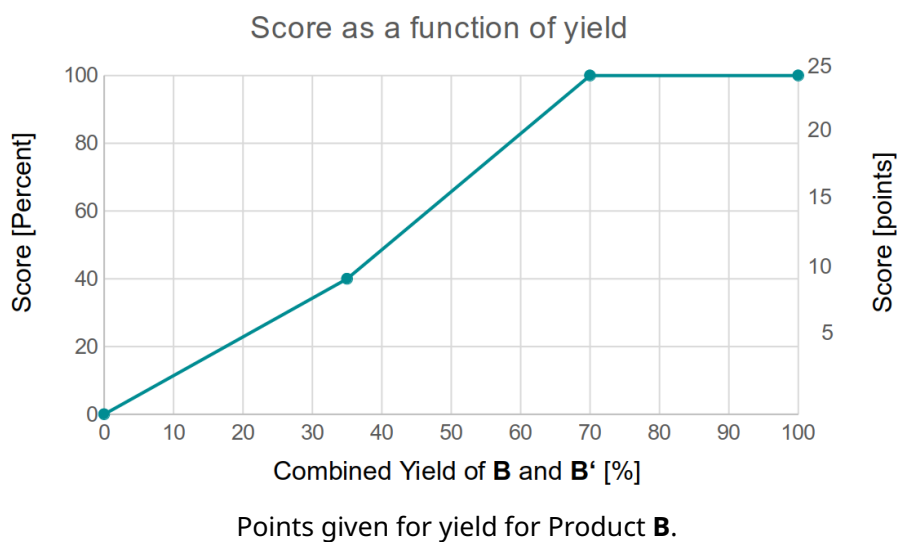

Thin Layer Chromatography (TLC) Analysis

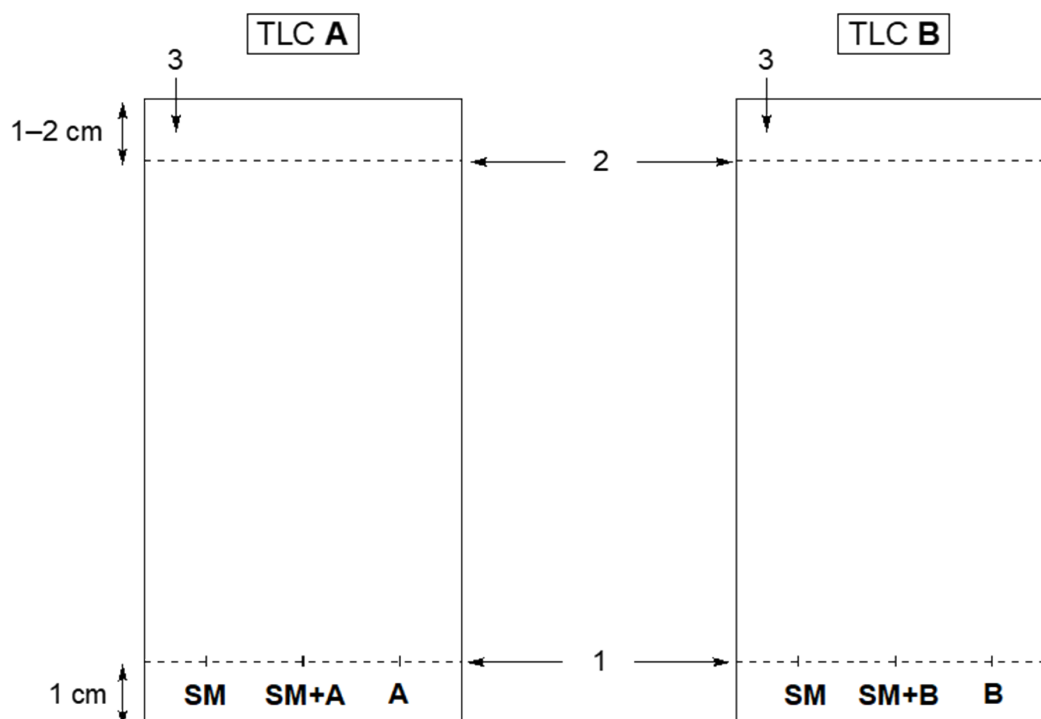
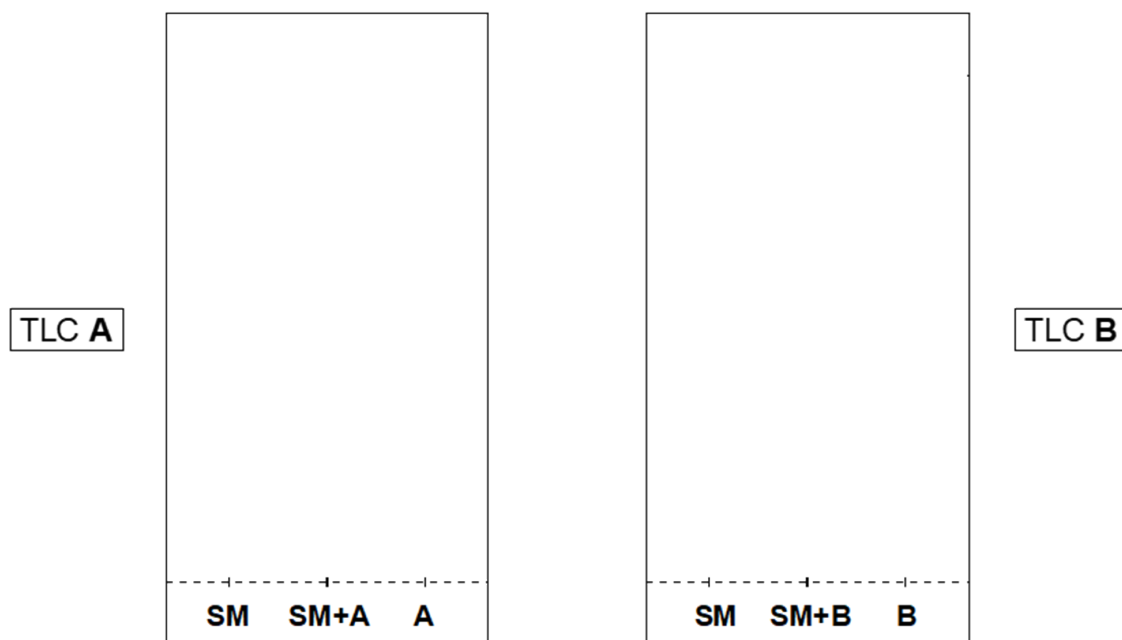

Figure 5: SM = starting material = *p*-methoxyacetophenone, A = product A, SM+A = co-spot of starting material and product A, B = product B, SM+B = co-spot of starting material and product B.

1 = starting line, 2 = front line, 3 = position to write down your student code.

1. **Prepare** the elution chamber: **Load** it to a level of ca. 0.5 cm with the eluent (mixture hexane/EtOAc in a 80:20 ratio, screw cap bottle “**Eluent**”) and **cover** it with the lid. If necessary, you can get extra eluent from your lab assistant without penalty.
2. **Prepare** your samples: Using a Pasteur pipette, **add** ca. 0.5 mL of eluent to each of the vials “**TLC-SM**”, “**TLC-A**”, and “**TLC-B**” to dissolve/dilute the respective samples. **Cap** the vial “**TLC-A**” and **shake** it (ca. 0.5 minute) for faster dissolution.
3. **Prepare** a TLC plate (stationary phase: SiO₂ on aluminium) for the analysis of product A (Figure 5, left): With pencil and ruler, gently **draw** the starting line ca. 1 cm above the bottom of the plate and **mark** the positions to spot 3 samples. **Label** them “**SM**” = starting material = *p*-methoxyacetophenone, “**A**” = product A, and “**SM+A**” = mixture (co-spot) of SM and product A. On the top left of the plate, **write down** your **Student Code**.
4. Similarly **prepare** another TLC plate for the analysis of product B (Figure 5, right).
5. Using capillary spotters, **spot** the two TLC plates on the starting line according to the labeling just done (Figure 5). **Use** a different capillary for each sample. **Wait** until the solvents have evaporated and the spots are dry.
6. **Develop** the TLC plates (either simultaneously or one after the other): Using tweezers, **insert** the TLC plate(s) into the elution chamber and **cover** it with the lid. **Let** the eluent **reach** a level of of 1–2 cm below the top of each plate. **Remove** the lid and, using tweezers, **remove** the plate(s) from the chamber. **Mark** the eluent front gently with a pencil and **let** the plate(s) air-dry.
7. **Visualize** the dry TLC plates under the UV lamp kept on a common bench. With a pencil, gently **circle all** visible spots.
8. **Complete** the templates **on the answer sheet** by sketching in the spots observed under the UV light. **Use** these sketches to answer the TLC-related questions on the answer sheet.



9. Carefully **place** your dry TLC plates into the zip lock bag with your student code. **Avoid** that the plates scratch each other.

10. **Have** the following items **ready** to be picked up by your lab assistant:

- The **glass vial and the volumetric flask with your products**. They are labeled with your student code and the designation of the respective product (“**Product A**” and “**Product B**”).
- A **zipped bag** labeled with your student code and **containing the two TLC plates** (TLC analysis of products **A** and **B**).

Note added *post festum*: The elaboration of the present exam question was inspired by the following publication: C. E. Ballard, *J. Chem. Educ.* **2010**, *87*, 190. The yields of products **A** and **B** were determined by ¹H-NMR spectroscopy and gas chromatography (GC), respectively, using internal standards.

Yield.A 25pt

TLC.A 3pt

Ded.A -6pt

Yield.B 25pt

TLC.B 3pt

Ded.B -25pt

Questions

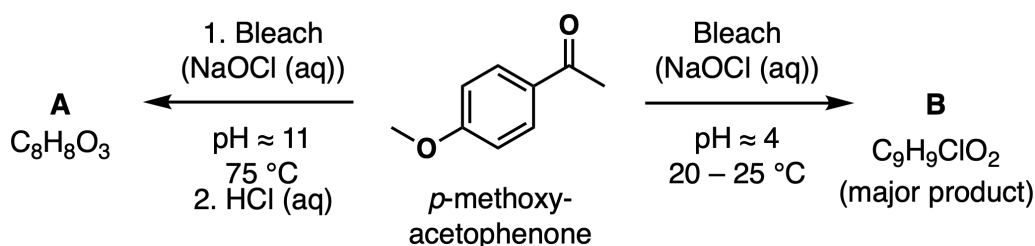

Legend for translation: Bleach, p -methoxyacetophenone, major product

Answer each of the following questions by ticking the appropriate checkbox (1 correct answer per question; ambiguous answers will be marked as incorrect).

- 1.1** Answer questions a – d based on the above **sketch** of your TLC plates (stationary phase: SiO_2 on aluminium; eluent: hexane/EtOAc in a 80:20 ratio). No points will be attributed if the sketch is not done. 4pt
- Which of the two products is more polar, **A** or **B**? **Choose** the correct answer.
Product **A** is more polar.
 - Which of the following two compounds is more polar, product **A** or the starting material (**SM**)? **Choose** the correct answer.
Product **A** is more polar.
 - Does your product **A** contain some remaining starting material? **Choose** the correct answer.
Depends on TLC sketch.
 - Does your product **B** contain some remaining starting material? **Choose** the correct answer.
Depends on TLC sketch.

- 1.2** Identify the structure of product **A** (empirical formula $C_8H_8O_3$). The possible answers can be found of the **answer sheet**. 2pt

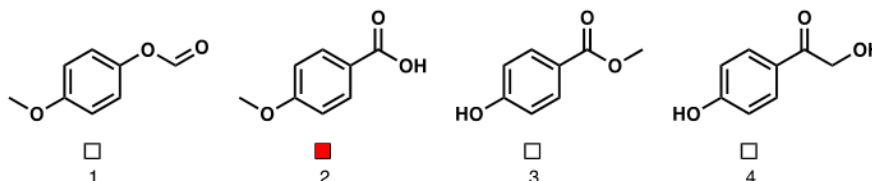

p-Methoxybenzoic acid (2)

- 1.3** As apparent from the empirical formula of product **A** ($C_8H_8O_3$), a C_1 fragment is cleaved off the starting molecule ($C_9H_{10}O_2$) in the course of the formation of **A**. After the reaction, the C_1 fragment ends up containing chlorine. **Identify** its structure. The possible answers can be found on the **answer sheet**. 2pt

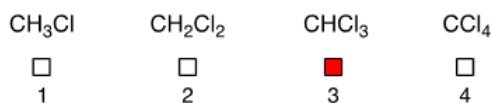

- 1.4** The formation of product **A** is a redox reaction. 2pt
- a. In this reaction, which atom type (element) is affected by an increase in oxidation number? **Choose** the correct answer on the answer sheet.



- b. In this reaction, which atom type (element) is affected by a decrease in oxidation number? **Choose** the correct answer on the answer sheet.



- 1.5** Identify the structure of product **B** (empirical formula $C_9H_9ClO_2$). The possible answers can be found on the **answer sheet**. 2pt

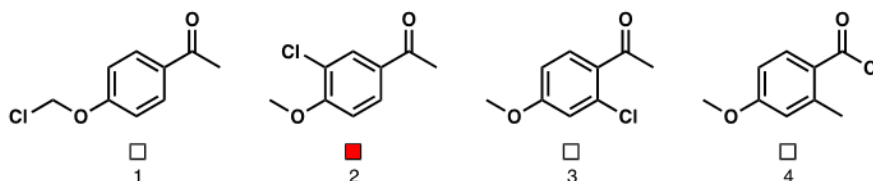

1-(3-Chloro-4-methoxyphenyl)ethan-1-one (2)

- 1.6** At some point in the synthesis of product **B**, $NaHSO_3$ (aq) is added to the reaction mixture. While serving its purpose, hydrogensulfite (HSO_3^-) undergoes a chemical reaction. What is the resulting sulfur-containing species? **Choose** the correct answer. **Note** that this question is **not** aimed at the protonation state of the resulting S-containing species (acid-base equilibria are ignored here). 2pt

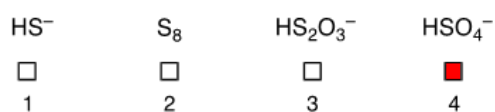

Titration Tango - Solutions

Points:

13 % of total										
Question	Titration 1	Titration 2	2.1	2.2	2.3	2.4	2.5	2.6	2.7	Total
Points	30	40	5	4	4	2	1	2	2	90
Score										

Introduction

Iron was historically mined and processed in 19 Swiss cantons, meeting local and regional demand. Evidence of this activity remains, particularly in the Swiss Jura. To produce iron and steel efficiently, knowledge of the composition of the iron ore is essential. A versatile method to analyze any metal in solution is the complexometric titration, pioneered by Prof. Gerold Schwarzenbach at ETH in the 1940s.

You are provided with a sample containing only hydrates of FeCl_3 and CaCl_2 , dissolved in aqueous HCl. This simulates an iron ore sample, which has been digested with hydrochloric acid. **Your task is to determine the iron concentration and the overall composition of the sample by complexometric titrations.**

Any aqueous waste of this task is considered to contain heavy metals and should be collected in the beaker labelled "Waste P2".

Procedure

Part I. Dilution of Unknown Iron Ore Sample

1. You are given a sample of ca. 1200 mg of simulated iron ore. The exact mass is written on the label of your vial. **Report** it in your **Answer Sheet**. The sample has already been dissolved in aqueous HCl of pH 1.
2. **Prepare** 100 mL of sample solution in the 100 mL volumetric flask using the whole content from the vial labelled "**Sample + [student code]**" and distilled water. You may use a funnel. This solution is called **A**. This solution will be used in part II and IV.

Mass of simulated iron ore [mg] (Report the value on the label)	1175.0 mg (800 mg $\text{FeCl}_3 \cdot 6\text{H}_2\text{O}$ + 375 mg $\text{CaCl}_2 \cdot 2\text{H}_2\text{O}$)
--	---

Part II. Direct Titration of Iron Ore Solution

- Fill** the burette with 10.0 mM EDTA solution, labelled as "**EDTA**". You may use a funnel and a beaker.
- In a 300 mL Erlenmeyer flask:
 - Add** 5.00 mL of solution **A** using a volumetric pipette;
 - Add** 10 drops of 0.1 M hydrochloric acid using a glass Pasteur pipette;
 - Fill up** to the 100 mL mark of your Erlenmeyer flask with distilled water;
 - Add** a small amount of variamine blue using a spatula.
- Titrate** the content of the Erlenmeyer flask until the solution becomes yellow. **Record** the titration volume V_1 in your **Answer Sheet**.
- Discard** the titrated content of the Erlenmeyer flask in the beaker labelled "**Waste P2**".
- Repeat** the procedure (steps 3 – 6) as needed.
- Report** your final result in the last row on the **Answer Sheet**.

Analysis Nr.	V_1 [mL]
1	
2	
3	
Reported value V_1 [mL]	14.8

Grading scheme: master value corrected for 800 mg $\text{FeCl}_3 \cdot 6\text{H}_2\text{O}$ plus 375 mg $\text{CaCl}_2 \cdot 2\text{H}_2\text{O}$: MV = 14.8 mL

Full score (30 pt) for MV \pm 0.3 mL (green zone below), Zero points beyond MV \pm 1.0 mL, linear in-between

(red zone below)

5 pt **penalty** if the reported value is missing, if this is the case, the average value of all reported titration values is used for further grading

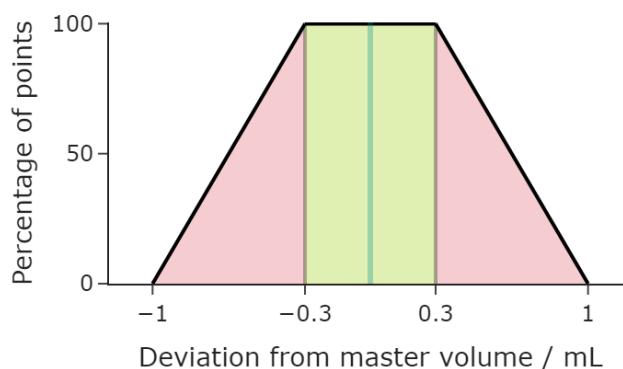
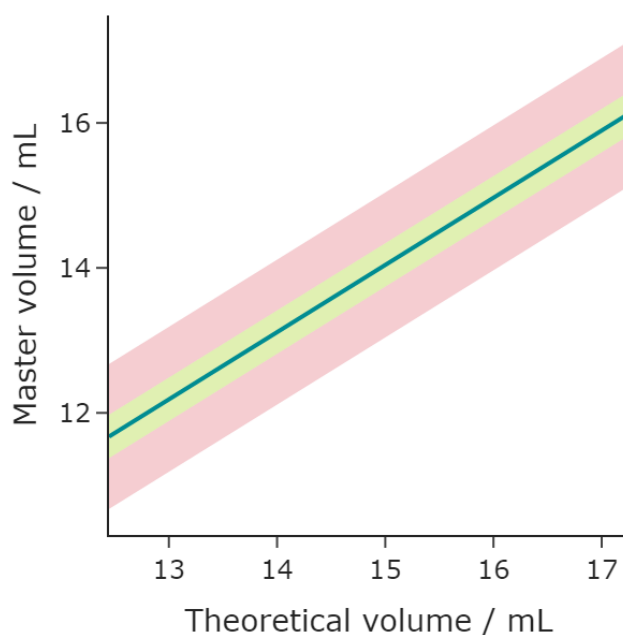

Part III. Titer preparation

9. You are given a sample of ca. 550 mg of pure calcium chloride dihydrate ($\text{CaCl}_2 \cdot 2\text{H}_2\text{O}$). The exact mass is written on the label of your vial. **Report** it in the table in your **Answer Sheet**.



10. **Prepare** 250 mL of calcium chloride solution in the 250 mL volumetric flask using the whole sample of solid $\text{CaCl}_2 \cdot 2\text{H}_2\text{O}$ (MW = 147.0 g/mol) and distilled water. You may need a funnel to transfer the solid. This solution is called **B**. It will be used in part IV.

Mass of calcium chloride dihydrate [mg] (Report the value on the label)	550 mg
--	--------

Part IV. Indirect Titration of Iron Ore Solution

11. **Empty** the burette. **Rinse** the burette well with distilled water and then with solution **B**. You may use a beaker. **Discard** the rinse solutions in the beaker labelled "**Waste P2**".
12. **Fill** the burette with solution **B**. You may use a funnel and a beaker.
13. In a 300 mL Erlenmeyer flask, **add**:
- 5.00 mL of solution **A** using a volumetric pipette;
 - 40.0 mL of 10.0 mM EDTA solution, labelled as "**EDTA**", using a volumetric pipette;
 - 10 drops of buffer solution using a glass Pasteur pipette (**be careful** when opening the buffer solution, as there can be evolution of ammonia);
 - 25 mL of distilled water using a graduated cylinder;
 - 30 mL of ethanol using a graduated cylinder.

Your sample may be turbid.

14. To the 300 mL Erlenmeyer flask, **add** a small amount of Eriochrome® Black T, from the vial labelled with "**Erio T**". Your sample should now be intense blue-green. **Perform** the titration **immediately** after the addition of the indicator.

Note: After addition of the indicator, the color will change to red after several minutes, regardless of the progress of the titration. At that point, the titration endpoint is no longer detectable.

15. **Titrate** the content of the Erlenmeyer flask until the solution turns grey. **Record** the titration volume V_2 . Your expected volume is below 15 mL.
16. **Discard** the titrated content of the Erlenmeyer flask in the beaker labelled "**Waste P2**".

Practical - SOLUTIONS



55TH INTERNATIONAL
CHEMISTRY OLYMPIAD
SWITZERLAND 2023

S2-5

English (Official)

17. **Repeat** the procedure (steps 12 – 16) as needed.
18. **Report** your final result in the last row on the **Answer Sheet**.

Analysis Nr.	V ₂ [mL]
1	
2	
3	
Reported value V₂ [mL]	8.3

Grading scheme: master value corrected for 550 mg CaCl₂·2H₂O as standard and 800 mg FeCl₃·6H₂O plus 375 mg CaCl₂·2H₂O as sample: 8.3 mL

Full score (40 pt) for MV ± 1.0 mL (green zone below), Zero points beyond MV - 2.0 mL and +5.0 mL, linear in-between (red zone below)

5 pt **penalty** if the reported value is missing, if this is the case, the average value of all reported titration values is used for further grading

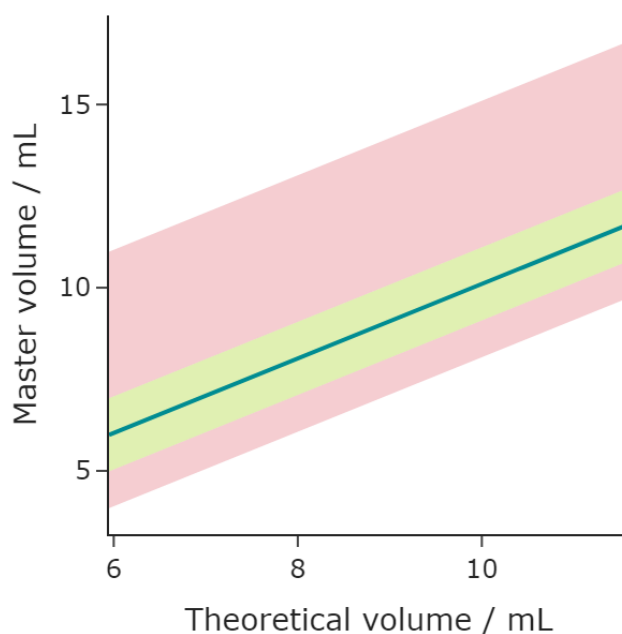

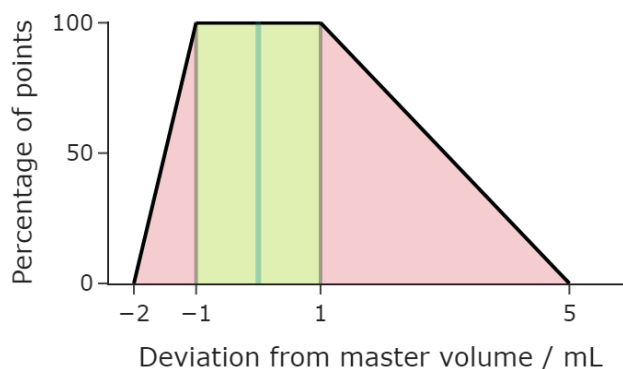

Questions

- 2.1** **Provide** the chemical formula of the resulting EDTA complex formed in the direct titration up to the equivalence point. The structure of EDTA is given below. In your chemical formula, abbreviate EDTA as "**H₄Y**", its conjugate bases as "**H₃Y⁻**", "**H₂Y²⁻**" etc. Hint: Under these conditions, one of the metal ions in solution preferentially forms an EDTA complex. 5pt

Complex formula: [Fe(Y)]- 5 pt

-2pt for wrong central metal

-1pt for wrong protonation

-1pt for wrong overall charge of the complex

-1pt for wrong stoichiometry

-1pt for using **EDTA** instead of **Y⁴⁻**, **H₃Y⁻** etc.

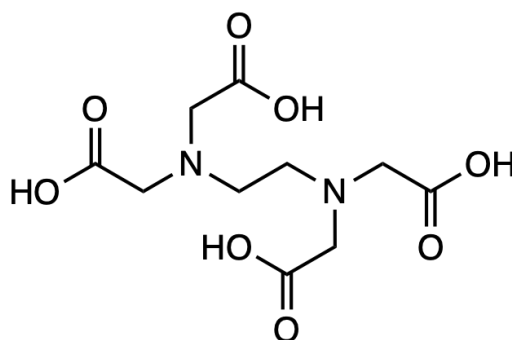

Structure of EDTA (equivalent to **H₄Y**).

- 2.2 Calculate** the mass percentage of iron(III) chloride (without water of crystallization), in wt%, of the provided sample. The molar mass of FeCl_3 is 162.2 g/mol. 4pt

$$c_{\text{sample}}(\text{Fe}^{3+}) = \frac{V_1}{V_{\text{sample, aliquot}}(\text{Fe}^{3+})} c(\text{EDTA}) = 29.6 \text{ mM } 1 \text{ pt}$$

$$n_{\text{sample}}(\text{Fe}^{3+}) = c_{\text{sample}}(\text{Fe}^{3+}) V_{\text{sample}}(\text{Fe}^{3+}) = 2.96 \text{ mmol } 1 \text{ pt}$$

$$m_{\text{sample}}(\text{FeCl}_3) = n_{\text{sample}}(\text{Fe}^{3+}) MW(\text{FeCl}_3) = 480 \text{ mg } 1 \text{ pt}$$

$$\text{wt}\%(\text{FeCl}_3) = \frac{m_{\text{sample}}(\text{FeCl}_3)}{m_{\text{sample}}} \cdot 100\% = 40.9\% \text{ } 1 \text{ pt}$$

- 2.3 Calculate** the mass percentage of calcium chloride (without water of crystallization), in wt%, of the provided sample. The molar mass of CaCl_2 is 111.0 g/mol. 4pt

$$c_{\text{sample}}(\text{Ca}^{2+}) = \frac{1}{V_{\text{sample, aliquot}}} [c(\text{EDTA})V_{\text{ex}}(\text{EDTA}) - c_{\text{sample}}(\text{Fe}^{3+})V_{\text{sample, aliquot}} - c_{\text{std}}(\text{Ca}^{2+})V_2] = 25.5 \text{ mM}$$

OR

$$c_{\text{sample}}(\text{Ca}^{2+}) = \frac{1}{V_{\text{sample, aliquot}}} [c(\text{EDTA})[V_{\text{ex}}(\text{EDTA}) - V_1] - c_{\text{std}}(\text{Ca}^{2+})V_2] = 25.5 \text{ mM } 2 \text{ pt}$$

$$n_{\text{sample}}(\text{Ca}^{2+}) = c_{\text{sample}}(\text{Ca}^{2+}) V_{\text{sample}}(\text{Ca}^{2+}) = 2.55 \text{ mmol } 0.5 \text{ pt}$$

$$m_{\text{sample}}(\text{CaCl}_2) = n_{\text{sample}}(\text{Ca}^{2+}) MW(\text{CaCl}_2) = 283 \text{ mg } 0.5 \text{ pt}$$

$$\text{wt}\%(\text{CaCl}_2) = \frac{m_{\text{sample}}(\text{CaCl}_2)}{m_{\text{sample}}} \cdot 100\% = 24.1\% \text{ } 1 \text{ pt}$$

- 2.4 Calculate** the mass percentage of water of crystallization, wt%, of the provided sample. 2pt

$$m_{\text{sample}}(\text{H}_2\text{O}) = m(\text{sample}) - m_{\text{sample}}(\text{FeCl}_3) - m_{\text{sample}}(\text{CaCl}_2) = 412 \text{ mg } 1 \text{ pt}$$

$$\text{wt}\% \text{H}_2\text{O} = \frac{m_{\text{sample}}(\text{H}_2\text{O})}{m(\text{sample})} \cdot 100\% = 35.1\% \quad 1 \text{ pt}$$

OR:

$$\text{wt}\% \text{H}_2\text{O} = 100\% - \text{wt}\%(\text{FeCl}_3) - \text{wt}\%(\text{CaCl}_2) = 35.1\% \quad 2 \text{ pt}$$

- 2.5** Why is it necessary to keep the sample solution **A** at pH < 2? 1pt

Identify the correct answer among the four choices below and **fill in** the corresponding checkbox in your **Answer Sheet**.

- To chemically stabilize Ca^{2+} in solution
- To chemically stabilize Fe^{3+} in solution
- To reduce Ca^{2+} in solution
- To reduce Fe^{3+} in solution

$[\text{Fe}(\text{OH}_2)_6]^{3+}$ is a weak acid which give off a proton yielding $[\text{Fe}(\text{OH}_2)_5(\text{OH})]^{2+}$. The new complex is unstable and eventually results in the precipitation of FeOOH .

- 2.6** The solution you were given simulates the digestion of iron ore with concentrated HCl. Which of the following mixtures could be analyzed by the same procedure? 2pt

Identify the correct answer among the four choices below and **fill in** the corresponding checkbox in your **Answer Sheet**.

- Hematite (Fe_2O_3) + Limestone (CaCO_3)
- Magnetite (Fe_3O_4) + Chalcopyrite (CuFeS_2)
- Ilmenite (FeTiO_3) + Goethite ($\text{FeO}(\text{OH})$)
- Siderite (FeCO_3) + Dolomite ($\text{CaMg}(\text{CO}_3)_2$)

Both Magnetite and Siderite contain Iron(II), which first needs to be fully oxidised to Iron(III) to be able to quantify it with the given method. Using the indirect titration to determine the amount of bivalent cations, any bivalent cations, which form stronger EDTA complexes than Ca^{2+} can be determined. This is the case for Cu^{2+} , TiO^{2+} and Zn^{2+} but not for Mg^{2+} . The titanium content will not dissolve. Thus, the correct choice is Hematite + Limestone.

- 2.7** Why does the sample for the indirect titration show a color change from blue to red regardless of the progress of the titration? 2pt

Identify the correct answer among the four choices below and **fill in** the corresponding checkbox in your **Answer Sheet**.

- Reduction of Fe^{3+} EDTA complex by ethanol
- Hydrolysis of Eriochrome® Black T under basic conditions
- Irreversible ligand exchange of Fe^{3+} EDTA complex by Eriochrome® Black

T

- Eriochrome® Black T adsorption onto precipitated CaCO_3

Reduction of Fe^{3+} EDTA complex by ethanol can be excluded since ethanol is not easily oxidized. Hydrolysis of Eriochrome® Black T under basic conditions can be excluded from the observations in the standardization procedure. Eriochrome® Black T adsorption onto precipitated CaCO_3 can be excluded since the samples are free of CO_2 and the absorption from air is slow. This leaves only one option. In fact, Eriochrome® Black T builds a strong enough complex with Fe^{3+} to compete with EDTA. The addition of an organic solvent kinetically inhibits this competition.

Beauty in simplicity - Solutions

11% of total				
Question	3.1	3.2	3.3	Total
Points	30	14	15	59
Score				

Introduction

You are provided with 6 solutions **S1–S6** of unknown composition. Solution **Sx** is labeled “[student code] + **Sx**”, with **x** going from 1 to 6. **Your task is to identify all cations and anions dissolved in these solutions.**

Hints:

- There are 7 cations and 7 anions which have been dissolved in aqueous solutions **S1–S6** from the list:
 - Cations: Ag^+ , Ba^{2+} , Ca^{2+} , Fe^{3+} , K^+ , Mn^{2+} , Na^+ ;
 - Anions: CH_3COO^- , Cl^- , I^- , NO_3^- , PO_4^{3-} , S^{2-} , SO_4^{2-} ;
- 2 or 3 ions in total were introduced into each solution.
- Each of the ions was introduced only into one solution.
- Na^+ and K^+ are present together in the same solution.
- In some cases, it might take up to 15 minutes before a visible change occurs; fill in the table in question 3.1 with your final observations.
- Some solutions can get colored or attain some precipitate due to oxidation under air.

Questions

3.1 **Perform** the cross-reactions between solutions **S1–S6**. **Fill in** the first table of your **answer sheet** with your observations using these symbols: 30pt

- “↓” for precipitation;
- “↑” for gas evolution;
- “S” for colour change of the solution;
- “–” if there are no visible observations.

Report the colours of the precipitates using the following letters:

- “W” for white/colorless;
- “B” for black;
- “C” for colored.

3.2 Based on your observations and the above-mentioned hints, **identify** the ions in **S1–S6** and **fill in** the second table in your **answer sheet**. 14pt

3.3 In the third table of your **answer sheet**, **write** the ionic equations of the performed reactions that explain your observations. Use “↓” for precipitates and “↑” for gases. 15pt

Practical - SOLUTIONS



55TH INTERNATIONAL
CHEMISTRY OLYMPIAD
SWITZERLAND 2023

S3-3

English (Official)

Solutions

Observations:

Solutions	S2	S3	S4	S5	S6
S1	C↓ yellowish	C↓ or W↓ pale yellow	W↓ white	C↓ or W↓ beige	W↓ white
S2	X	W↓ white	B↓ black	B↓ metallic black	+ C↓ pale yellow
S3	X	X	C↓ or B↓ dark brown, black	S red-brown	S brown
S4	X	X	X	C↓ or W↓ beige	W↓ white
S5	X	X	X	X	W↓ white

2 points for symbol "S" in S3-S5 and S3-S6. In all other cases, 1 point for noting a precipitation and 1 point for the right colour of this precipitation.

The following ions usually are coloured in aqueous solutions: Fe^{3+} - yellow/orange, Mn^{2+} - can be pinkish in concentrated solutions. Solution **S3** has intense yellow-orange colour, while solutions **S4** and **S6** can be also slightly yellow; thus, one of them contains Fe^{3+} . (The coloring of the other two solutions might come from the oxidation of the corresponding iodide and sulfide anions.) The only possible anions for the solution with Fe^{3+} are Cl^- , NO_3^- , SO_4^{2-} , PO_4^{3-} and S^{2-} anions give insoluble products with Fe^{3+} , I^- gets oxidized to I_2 and CH_3COO^- forms a distinctly red complex. Only solution **S3** forms dark brown precipitate with **S4**, intense red-brown solution with **S5** and brown solution with **S6**. These observations are consistent with the presence of Fe^{3+} in **S3** and S^{2-} in **S4**. Solutions **S5** and **S6**, therefore, should contain

CH_3COO^- and I^- . **S4** containing S^{2-} can form another black precipitate only with Ag^+ in **S2**.

Solution	S1	S2	S3	S4	S5	S6
Cations		Ag^+	Fe^{3+}			
Anions				S^{2-}	CH_3COO^- or I^-	CH_3COO^- or I^-

Next, one can use reaction with Ag^+ in order to identify I^- . Upon mixing **S2** containing Ag^+ and **S5**, a metallic precipitate, possibly **Ag**, is formed, while the only possible reducing agent amongst remaining ions is Mn^{2+} . Plus, the number of beige precipitates observed upon mixing **S5** with the other solutions suggests that Mn^{2+} is there. The formation of pale yellow precipitate from **S2** and **S6** and the absence of similarly textured and colored precipitate in the **S2+S5** mixture mean that **S6** contains I^- (this also explains the yellow color of **S6**: oxidation of I^- by air) and **S5** – CH_3COO^- .

Solution	S1	S2	S3	S4	S5	S6
Cation(s)		Ag^+	Fe^{3+}		Mn^{2+}	
Anion(s)				S^{2-}	CH_3COO^-	I^-

Ag^+ can also form precipitates with Cl^- (white), SO_4^{2-} (white) and PO_4^{3-} (yellow). Indeed, solution **S2** forms yellow precipitate with **S1**, white – with **S3**, and yellowish – with **S6**. Therefore, **S1** contains PO_4^{3-} . The only cations that do not form precipitates in mixture with PO_4^{3-} are Na^+ and K^+ .

Solution	S1	S2	S3	S4	S5	S6
Cation(s)	Na^+, K^+	Ag^+	Fe^{3+}		Mn^{2+}	
Anion(s)	PO_4^{3-}			S^{2-}	CH_3COO^-	I^-

We are left with two cations, Ca^{2+} and Ba^{2+} , that should be contained in solutions **S4** and **S6**. Indeed, both solutions form white precipitates with PO_4^{3-} (**S1**). CaS hydrolyzes stronger than BaS due to a lower solubility of $\text{Ca}(\text{OH})_2$. Therefore, most probably Ba^{2+} is contained together with S^{2-} in **S4** and Ca^{2+} is together with I^- in **S6**. This can be further confirmed by mixing **S4** and **S6** leading to a slow formation of white precipitate ($\text{Ca}(\text{OH})_2$).

Practical - SOLUTIONS



55TH INTERNATIONAL
CHEMISTRY OLYMPIAD
SWITZERLAND 2023

S3-5

English (Official)

Solution	S1	S2	S3	S4	S5	S6
Cation(s)	Na ⁺ , K ⁺	Ag ⁺	Fe ³⁺	Ba ²⁺	Mn ²⁺	Ca ²⁺
Anion(s)	PO ₄ ³⁻			S ²⁻	CH ₃ COO ⁻	I ⁻

Mixing of **S2** (Ag⁺) and **S3** leads to the formation of white precipitate at the bottom of the tube. The only possible anions amongst the remaining ones that form precipitate with Ag⁺ are Cl⁻ and SO₄²⁻. Thus, **S3** contains Cl⁻, SO₄²⁻ or a mixture of both of them. Instead, **S2** should contain NO₃⁻. Presence of Cl⁻ and SO₄²⁻ in **S3** cannot be tested directly due to the formation of other colored products upon mixing of **S3** with other solutions. Yet, mixing solution **S5** with solution **S6** containing Ca²⁺ leads to a slow formation of colorless precipitate which cannot be explained by the already identified ions. The only option for this precipitate is CaSO₄, therefore SO₄²⁻ is contained in **S5**. This experiment also serves as an additional proof of absence of Ba²⁺ in **S6**, otherwise a quick formation of highly insoluble white BaSO₄ is expected. The remaining anion Cl⁻ then should be in **S3**. The final table looks as follows:

Solution	S1	S2	S3	S4	S5	S6
Cation(s)	Na ⁺ , K ⁺	Ag ⁺	Fe ³⁺	Ba ²⁺	Mn ²⁺	Ca ²⁺
Anion(s)	PO ₄ ³⁻	NO ₃ ⁻	Cl ⁻	S ²⁻	CH ₃ COO ⁻ , SO ₄ ²⁻	I ⁻

1 point for each correctly identified ion

Practical - SOLUTIONS



55TH INTERNATIONAL
CHEMISTRY OLYMPIAD
SWITZERLAND 2023

S3-6

English (Official)

Solutions	S2	S3	S4	S5	S6
S1	C↓ yellowish Ag ₃ PO ₄ ↓	C↓ or W↓ pale yellow FePO ₄ ↓	W↓ white Ba ₃ (PO ₄) ₂ ↓	C↓ or W↓ beige Mn ₃ (PO ₄) ₂ ↓	W↓ white Ca ₃ (PO ₄) ₂ ↓
S2		W↓ white AgCl↓	B↓ black Ag ₂ S↓	B↓ metallic Ag↓ + black MnO ₂ ↓	C↓ pale yellow AgI↓
S3			C↓ or B↓ brown Fe(OH) ₃ ↓ black FeS	S, red-brown solution of Fe ₃ O(AcO) ₆	S, brown solu- tion of I ₂
S4				C↓ or W↓ white BaSO ₄ ↓ + beige MnS↓	W↓ white Ca(OH) ₂ ↓
S5					W↓ white CaSO ₄ ↓

Combination	Ionic Reaction Equation(s)
S1+S2	$3\text{Ag}^+ + \text{PO}_4^{3-} = \text{Ag}_3\text{PO}_4 \downarrow$
S1+S3	$\text{Fe}^{3+} + \text{PO}_4^{3-} = \text{FePO}_4 \downarrow$ (hydroxyphosphates are also accepted)
S1+S4	$3\text{Ba}^{2+} + 2\text{PO}_4^{3-} = \text{Ba}_3(\text{PO}_4)_2 \downarrow$ (hydroxyphosphates are also accepted)
S1+S5	$3\text{Mn}^{2+} + 2\text{PO}_4^{3-} = \text{Mn}_3(\text{PO}_4)_2 \downarrow$ (hydroxyphosphates are also accepted)
S1+S6	$3\text{Ca}^{2+} + 2\text{PO}_4^{3-} = \text{Ca}_3(\text{PO}_4)_2 \downarrow$ (hydroxyphosphate is also accepted)
S2+S3	$\text{Ag}^+ + \text{Cl}^- = \text{AgCl} \downarrow$
S2+S4	$2\text{Ag}^+ + \text{S}^{2-} = \text{Ag}_2\text{S} \downarrow$
S2+S5	$\text{Mn}^{2+} + 2\text{Ag}^+ + 2\text{H}_2\text{O} = \text{MnO}_2 \downarrow + 2\text{Ag} \downarrow + 4\text{H}^+$ Mn(III) is also accepted
S2+S6	$\text{Ag}^+ + \text{I}^- = \text{AgI} \downarrow$
S3+S4	$2\text{Fe}^{3+} + 3\text{S}^{2-} = 2\text{FeS} \downarrow + \text{S} \downarrow$ $2\text{Fe}^{3+} + 3\text{S}^{2-} + 6\text{H}_2\text{O} = 2\text{Fe}(\text{OH})_3 \downarrow + 3\text{H}_2\text{S}(\uparrow)$ (formation of HS^- is also accepted) Either of these reactions is accepted
S3+S5	$3\text{Fe}^{3+} + 6\text{AcO}^- + \text{H}_2\text{O} = [\text{Fe}_3\text{O}(\text{AcO})_6]^+ + 2\text{H}^+$ (accept all plausible coordination compounds)
S3+S6	$2\text{Fe}^{3+} + 3\text{I}^- = 2\text{Fe}^{2+} + \text{I}_3^-$ Formation of I_2 is also accepted
S4+S5	$\text{Ba}^{2+} + \text{SO}_4^{2-} = \text{BaSO}_4 \downarrow$ $\text{Mn}^{2+} + \text{S}^{2-} = \text{MnS} \downarrow$ 0.5 point for one reaction, 1 point if both reactions are present
S4+S6	$\text{Ca}^{2+} + \text{S}^{2-} + 2\text{H}_2\text{O} = \text{Ca}(\text{OH})_2 \downarrow + \text{H}_2\text{S}(\uparrow)$ Formation of HS^- is also accepted
S5+S6	$\text{Ca}^{2+} + \text{SO}_4^{2-} = \text{CaSO}_4 \downarrow$ Crystallohydrates are also accepted

Maximum 1 point for every combination (15 combinations = 15 points)

Minus 0.1 point for each missing arrow (except for H_2S).

Minus 0.25 points if equation is not balanced.

If an equation for a misidentified ion(s) is chemically correct and consistent with all experimental observations then it is graded with full points. Yet, if the same equation appears several times, it can be graded as a correct one only once.